

W3900



Lampada essiccazione a raggi infrarossi

Heater-dryer with infrared emitters

Sécheur à infrarouges

Infrarot-Strahler



Gestione computerizzata
3 x 1000 W
Centralina digitale
Possibilità selezione programma di essiccazione
2 temporizzazioni e un modulatore di potenza
garantiscono risultati ottimali

PCU- management
3 x 1000 W infrared tubes
Digital control panel
Selection of memorised curing procedure
2 timers and emitting power regulator grant
excellent results

Géré par microprocesseur
3 x 1000 W
Boîtier digital
Sélection du programme mémorisé
2 temporisations et un doseur de puissance
pour un séchage optimal

Prozessorgesteuert
3 x 1000 W-Lampen
Digitalsteuerung
Trocknungsprogramm-Abruf
2 Zeitsteuerungen und ein Leistungsregler
gewährleisten eine einwandfreie Trocknung

WERTHER



W3900

Dati tecnici - Technical data - Caractéristiques techniques - Technische Eigenschaften

Caratteristiche tecniche	Technical data	Caractéristiques technique	Technische Eigenschaften	W3900
Lampade: Al quarzo	Lamp: Quartz	Lampes: a Quartz	Strahler: Quarzlampen	1840 °C
Pannelli radianti	Emitters	Panneaux radiants	Anzahl Strahler	3
Potenza dei pannelli	Power of emitters (each)	Puissance des panneaux	Strahlerleistung (pro Strahler)	1000W
Potenza totale	Total power	Puissance totale	Gesamtleistung drei Kassetten	3000W
Voltaggio	Voltage	Courant	Betriebsspannung	240V
Ampere	Ampere	Ampérage	Stromaufnahme	12,5A
Zona radiante	Radiant area	Zone radiante	Trockenfläche	600x900 mm
Estensione	Extension	Extension	Ausdehnung	1900 mm
Dimensioni	Sizes	Dimensions	Abmessungen	1650x750x1120 mm
Distanza di essiccazione	Dryer distance	Distance de séchage	Reichweite	800 mm
Riflettori: Argentati	Reflectors: Aluminised	Réflecteurs Argentés	Strahler: silberbeschichtet	
Orientabilità: Verticale ed orizzontale	Orientation: Vertical / horizontal	Orientabilité: Verticale et horizontale	Ausrichtbarkeit: vertikal und horizontal	



WERATHER INTERNATIONAL S.p.A.

Via F. Brunelleschi, 12 - 42040 Cadè (RE) Italy - Tel. ++39 0522 9431 - Fax ++39 0522 941997
www.wertherint.com - e-mail: sales@wertherint.com

Il fabbricante, nell'ambito del costante miglioramento dei propri prodotti, si riserva il diritto di apportare modifiche senza preavviso. - The company reserves the right to introduce improvements in design or specification without prior notice. - Der Hersteller behält sich das Recht vor, im Zuge der technischen Weiterentwicklung, technische Eigenschaften ohne Vorankündigung zu ändern. - Le fabriquant dans le but d'améliorer constamment ses produits, se réserve le droit d'apporter des modifications sans préavis - La compañía Werther se reserva de todos modos el derecho de aportar todas las modificaciones que considera necesarias para mejorar la estética o el funcionamiento de los productos, sin tener la obligación de avisar de ello.

■ W116-W116A-W117-W117A



W116

- Raddrizzatore idraulico 10 t con pompa manuale
- 10 ton body straightener with hydraulic pump
- Equerre de redressage 10 t avec pompe hydraulique
- Hydraulisches 10 t-Zuggerät mit Hydraulikpumpe

W116A

- Raddrizzatore idraulico 10 t con pompa idropneumatica
- 10 ton body straightener with hydro-pneumatic pump
- Equerre de redressage 10 t avec pompe hydropneumatique
- 10 t-Zuggerät mit hydropneumatischer Pumpe

W117

- Raddrizzatore idraulico 10 t con braccio orientabile e pompa idraulica
- 10 ton tilting body straightener with hydraulic pump
- Equerre de redressage 10 t avec bras orientable et pompe hydraulique
- Hydraulisches 10 t-Zuggerät mit Hydraulikpumpe

W117A

- Raddrizzatore idraulico 10 t con braccio orientabile e pompa idropneumatica
- 10 ton tilting body straightener with hydro-pneumatic pump
- Equerre de redressage 10 t avec bras orientable et pompe hydropneumatique
- Hydraulisches 10 t-Zuggerät mit Schwenkarm und hydropneumatischer Pumpe

WERTHER



W116-W116A-W117-W117A

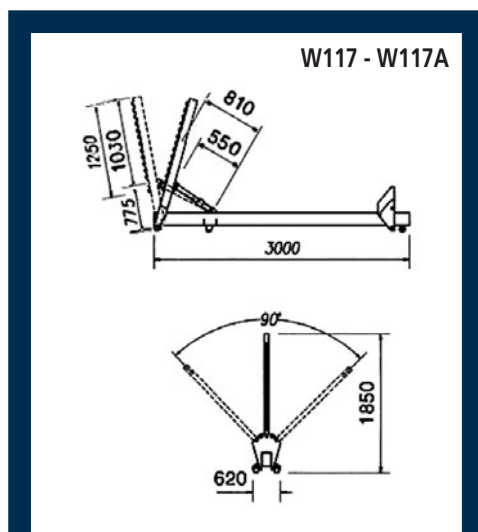

Dati tecnici - Technical data - Caractéristiques techniques - Technische Eigenschaften

Caratteristiche tecniche	Technical data	Caractéristiques technique	Technische Eigenschaften	W116	W116A	W117	W117A
Forza di trazione	Capacity	Capacité	Zugkraft	10 t	10 t	10 t	10 t
Braccio orientabile	Tilting anchor post	Bras pivotant	Schwenkarm	X	X		
Braccio fisso	Fixed anchor post	Bras fixe	Kipparm			X	X
Pompa manuale	Manual pump	Pompe manuelle	Handpumpe	X		X	
Pompa pneumoidraulica	Hydropneumatic pump	Pompe hydropneumatique	Hydropneumatische Pumpe		X		X

WERTHER



■ W118 - W119

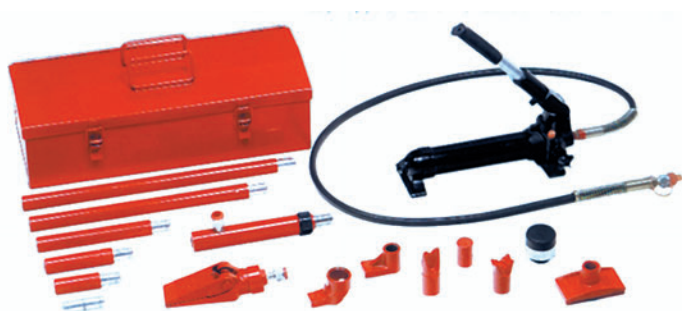

Kit idraulico per carrozzeria in cassetta metallica

Hydraulic body repair kit with metal case

Vérins de carrossier en mallette métallique

Karosserie-Hydraulikstempelsatz mit Metallkoffer

Dati tecnici - Technical data - Caractéristiques techniques - Technische Eigenschaften

Caratteristiche tecniche	Technical data	Caractéristiques technique	Technische Eigenschaften	W118	W119
Forza di spinta	Capacity	Capacité	Zugkraft	10 t	4 t



WERTHER INTERNATIONAL S.p.A.

Via F. Brunelleschi, 12 - 42040 Cadè (RE) Italy - Tel. ++39 0522 9431 - Fax ++39 0522 941997
www.wertherint.com - e-mail: sales@wertherint.com

Il fabbricante, nell'ambito del costante miglioramento dei propri prodotti, si riserva il diritto di apportare modifiche senza preavviso. - The company reserves the right to introduce improvements in design or specification without prior notice. - Der Hersteller behält sich das Recht vor, im Zuge der technischen Weiterentwicklung, technische Eigenschaften ohne Vorankündigung zu ändern. - Le fabricant dans le but d'améliorer constamment ses produits, se réserve le droit d'apporter des modifications sans préavis. - La compañía Werther se reserva de todos modos el derecho de aportar todas las modificaciones que considera necesarias para mejorar la estética o el funcionamiento de los productos, sin tener la obligación de avisar de ello.

605



Carrello per spostamento vetture

Dolly trolley

Chariot pour déplacement carrosserie

Karosserie-Fahrwagen

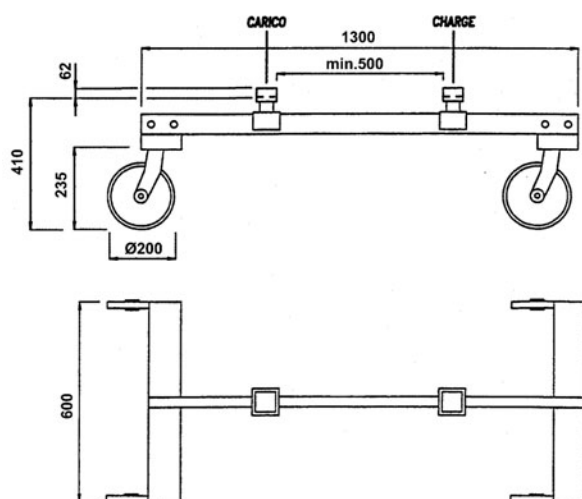

WERATHER

